

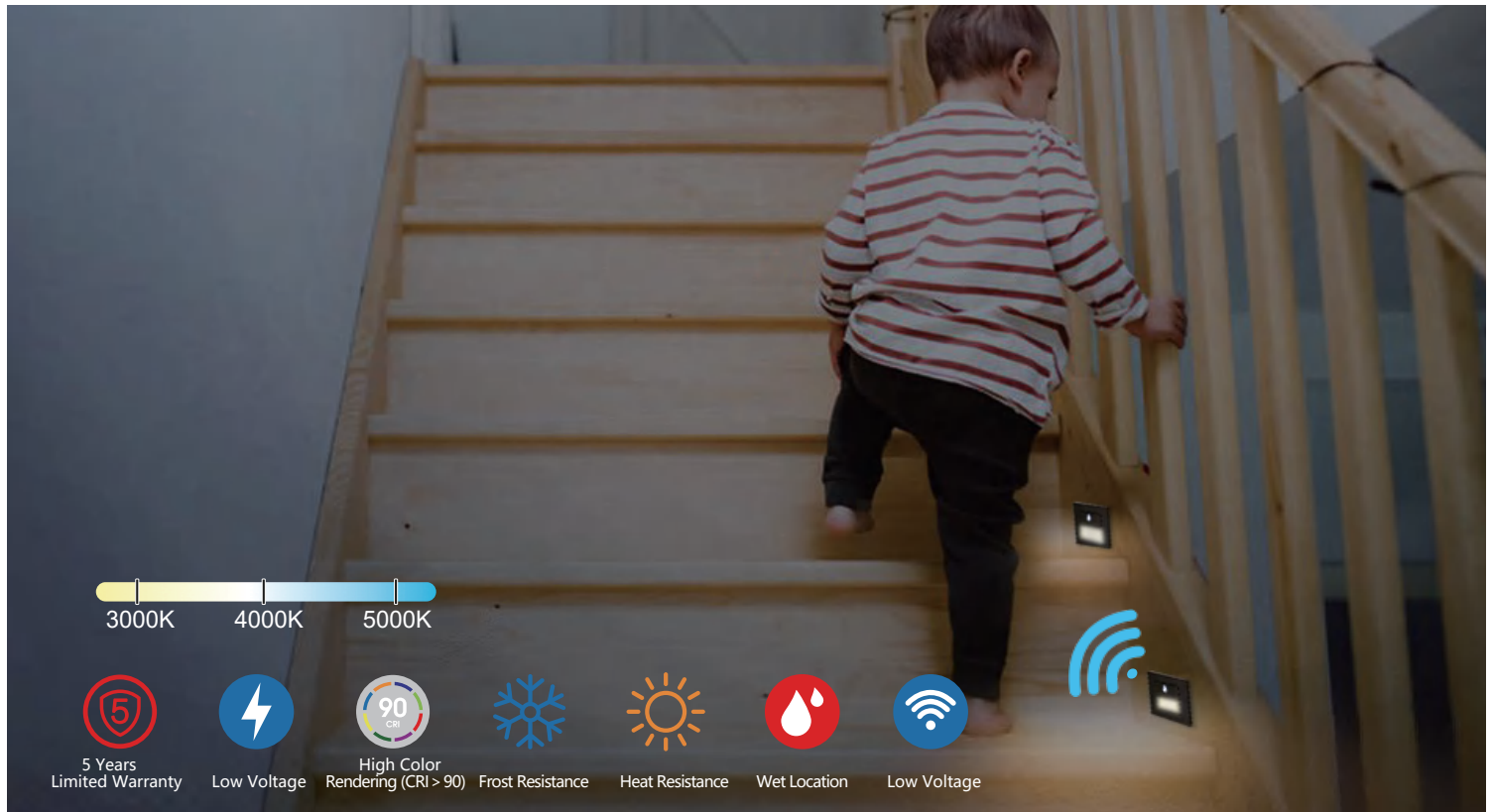

Project | Catalog # | Prepared by | Notes | Order # | Date

LED Step Light Series

120V 5CCT Line Voltage Horizontal /Vertical Step Light



DESCRIPTION

The Horizontal LED stair lights have a sleek, modern design that is a great addition to any home or building. They can be installed in your steps or in the wall to provide beautiful lighting to your stairs. These step lights feature a color selectable switch so you can choose the proper light color of 3000K soft white, 4000K cool white, or 5000K daylight . These stairwell lights provide 50 Lumens of light output and have a high CRI rating of 90, producing an accurate rendering of colors in your room. The motion sensor features a 120° sensor angle and will automatically light up upon sensing motion. They're waterproof and made of corrosion-resistant aluminum making them ideal for wet locations. They are popular as deck lights, patio step lights and stairwell lighting and for use down long hallways or as supplemental lighting in bathrooms.

The step and wall lights can be installed onto a standard 2in x 4in electrical junction box, they are ETL Listed and can be used for indoor and outdoor applications and come with 5-year limited warranty.



17578 Rowland St., City of Industry, CA 91748

Email: support@runbisonlighting.com



LED Step Light Series

120V 3CCT Line Voltage Horizontal Step Light with motion sensor



SPECIFICATION FEATURES

3CCT

- Select color temperature from 3000K soft white, 4000K cool white, or 5000K daylight for your environment.

Integrated PIR Motion and Photocell Sensor

- At night, when motion is detected, the light will turn on for 35 seconds and then shut off. During the day, the light will not turn on, even when motion is detected, saving you money & energy.

CONSTRUCTION

- Sleek, solid die-cast aluminum line voltage fixture directs light down.
- Standard metallic and non-metallic 2in x 4in electrical boxes are recommended for installation.

FINISH

- Coated with oil-rubbed bronze finish perfect for corrosion resistance.

AMBIENT TEMP

- -20 °C - 40 °C
- Wet location rated for indoor and outdoor use.

WARRANTY

- 5-year warranty

CERTIFICATION

- ETL/FCC Listed

ORDERING INFORMATION

Series	MSLV-3W-3CCT-MS
Input Frequency	AC120V, 60Hz
CRI	90
Power	3W
CCT	30K/40K/50K
Lumens	50 lm
Beam Angle	90°
Width(Inch)	4.7
Width(Inch)	1.6
Height(Inch)	2.88
Weight(LBS)	0.47

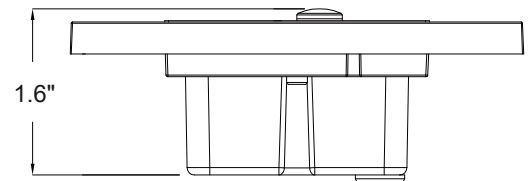
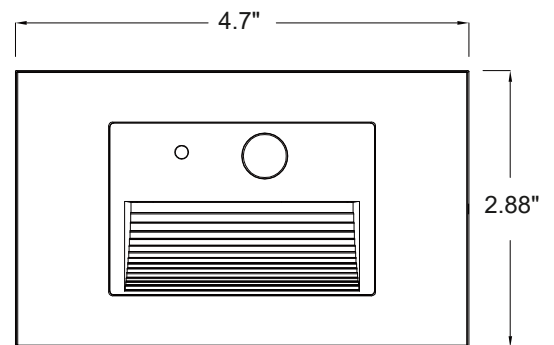



LED Step Light Series

120V 3CCT Line Voltage Horizontal Step Light with motion sensor



INSTALLATION

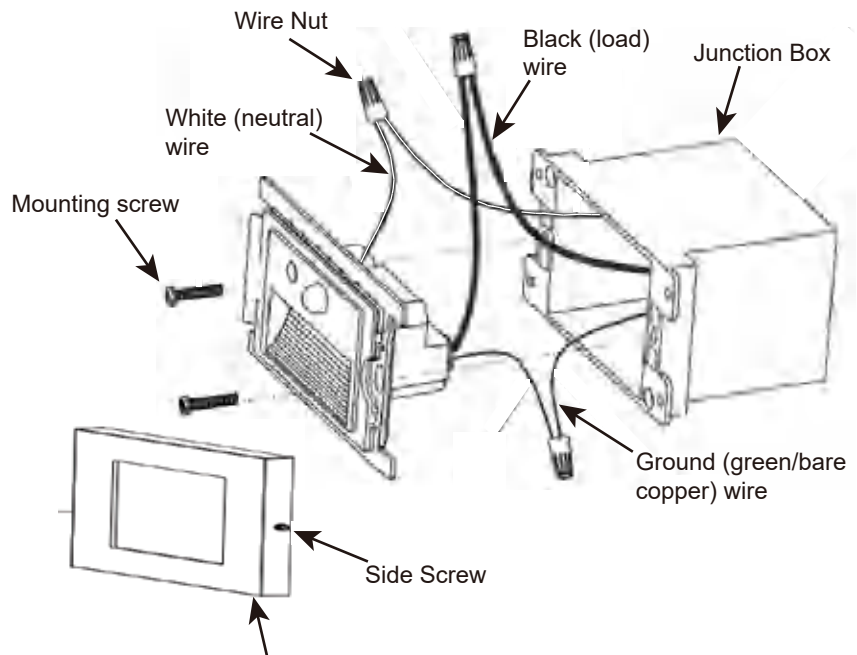
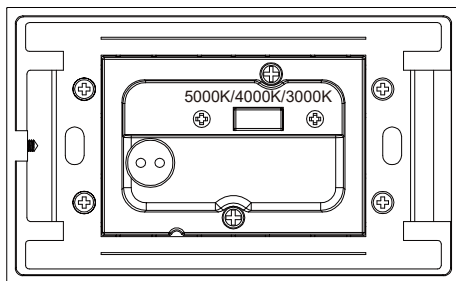

1. Shut off power at the circuit breaker or fuse by switching the circuit breaker to the off position or by removing the fuse before installation.
2. If you are replacing a fixture, remove and disconnect the old fixture.
3. Before installation begins select the desired color temperature by moving the switch on the back as shown in figure 1.
4. Remove the front face plate by unscrewing the side screw (see figure 2) using the supplied allen key.
5. Connect the line voltage to the fixture by connecting the black to the black, white to the white, and the green to the green or bare copper wire using the provided wire nuts as shown in figure 2.
6. Once the wires are connected carefully tuck the wires into the junction box and secure fixture to box using the provided screws.
7. Align the face plate with the bracket then press the faceplate onto the bracket and rescrew side screw,securing them together.
8. Repeat this process for each step light being installed.
9. Restore power to the fixture(s) that have been installed.
10. Installation is now complete restore power and check operation of the fixture(s).

WARRANTY

This product is warranted for 5 years from the date of purchase. If this product does not perform to the specifications supplied on this package, send an email to support@runbisonlighting.com for product return and replacement. This replacement is the sole remedy available. Liability for incidental or consequential damage is expressly excluded.

