

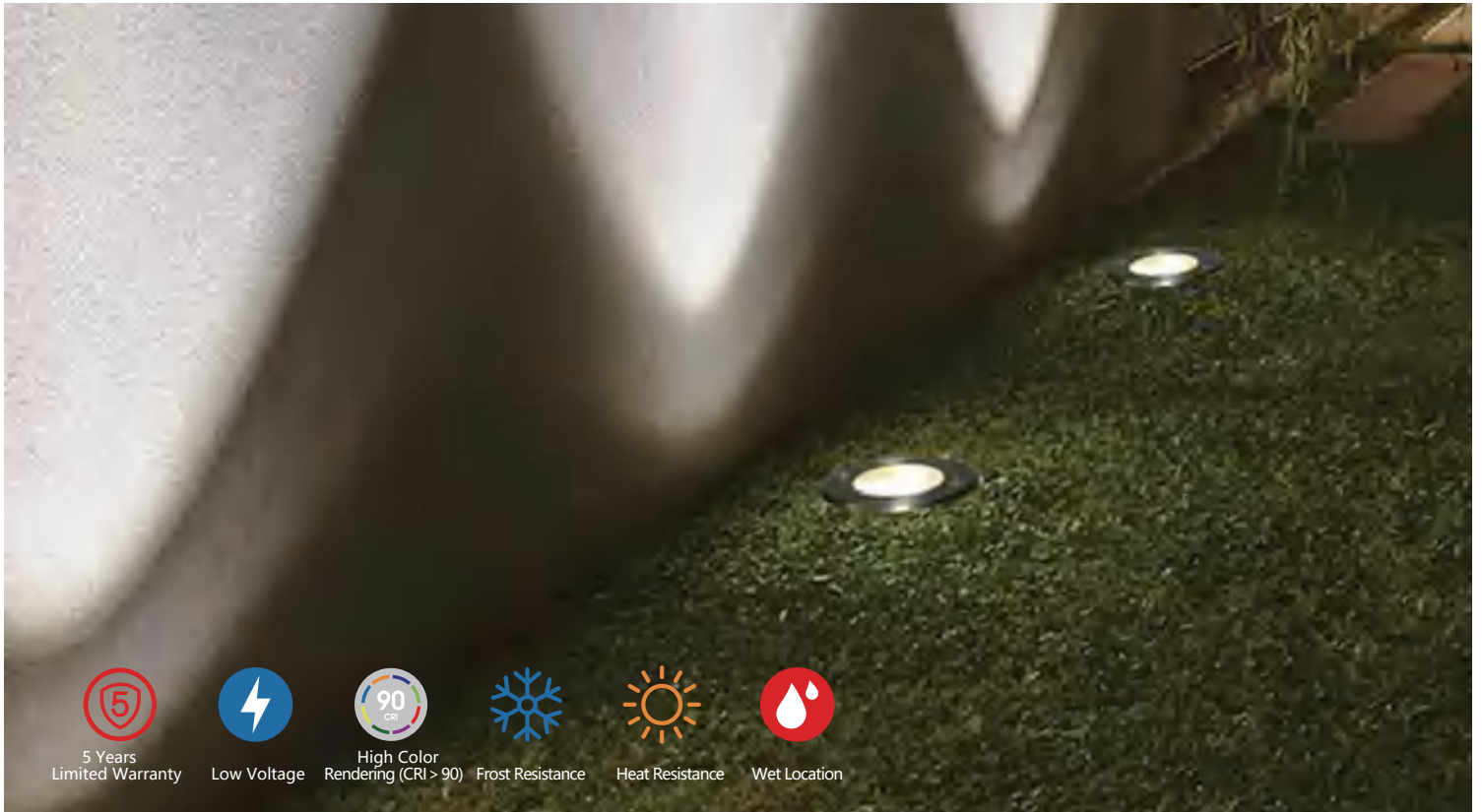

Project | Catalog # | Prepared by | Notes | Order # | Date

# LED Landscape In ground Well Light Series

## LED Low Voltage Landscape Well Light-Grated Top



### DESCRIPTION

This LED Landscape Lighting is solution for Outdoor lighting, LED technology means no bulbs to replace making the light virtually maintenance free. The high CRI of 90+ lets this low voltage well Light bring out the natural color of objects. Rugged aluminum housing with corrosion resistance & heat dissipation. IP65 rating brings better waterproof performance, best choice for outdoor wet locations, resistant to damage of heavy rains.

This in-ground well light operates at a low voltage range of 12V-24V AC/DC, making it a safe option for households with children and pets. You can rest assured that your little ones and furry friends can explore every corner of your yard without any worries. With 50,000hrs long lifespan and backed by a 5-year warranty.



17578 Rowland St., City of Industry, CA 91748

Email: [support@runbisonlighting.com](mailto:support@runbisonlighting.com)



## LED Landscape In ground Well Light Series

LED Low Voltage Landscape Well Light-Grated Top



### SPECIFICATION FEATURES

#### LOW VOLTAGE LANDSCAPE LIGHTING

- The 6W LED provides 350 lumen of warm white light (3000K) for a cozy ambiance. Energy-efficient and longlasting, these lights consume less power while providing bright illumination.

#### CONSTRUCTION

- Constructed from the Aluminum materials to ensure durability and longevity.
- Feature fast-lock connectors, facilitating a hasslefree DIY project.

#### FINISH

- Coated with Oil Rubbed Bronze finish perfect for corrosion resistance.

#### AMBIENT TEMP

- 20 °C-40 °C

#### PARAMETERS

- AC/DC 12V/24V low output voltage
- Compatible with a 12V transformer, the transformer is not included.

#### WARRANTY

- 5-year warranty

#### CERTIFICATION

- ETL/FCC Listed

### ORDERING INFORMATION

Series	MLWL-6W-30K-LVER
Input Frequency	AC/DC12-24V
CRI	90
Power	6W
CCT	3000K
Lumens	350LM
Beam Angle	60°
Φ(Inch)	4.02
Height(Inch)	3.5
Weight(lbs)	0.7

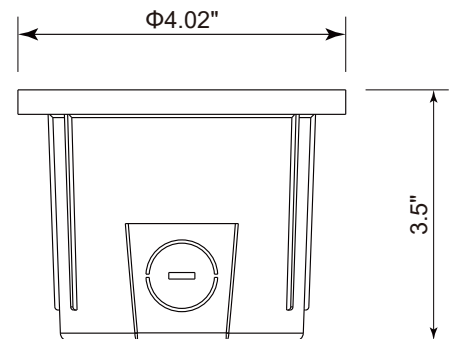



## LED Landscape In ground Well Light Series

### LED Low Voltage Landscape Well Light-Grated Top



## INSTALLATION

### FIXTURE MOUNTING INSTRUCTIONS (MASONRY OR HARDSCAPES)

1. Dig a 4.25" wide and 3.25" deep hole.(Fig.1)

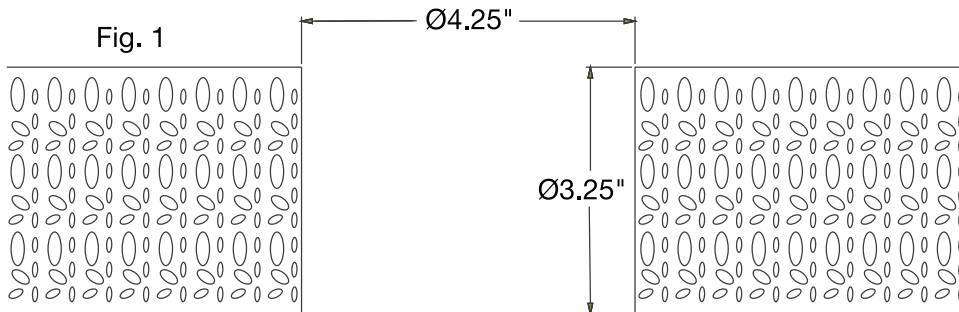

2. Pull the fixture out from the embedded part. Remove the waterproof wire nuts from the embedded part. Then remove enough knockoutsto accommodate wires.
3. **TURN OFF THE POWER.** Pass the power supply through the embedded part. Then, place the embedded part in the hole. Use concrete to fill the gap between the embedded part and the hole.
4. Use waterproof wire nuts to connect the lamp wires with the power supply.
5. Color Selection

6. Buckle the fixture into the embedded part. Then turn the power back on. (Fig. 2)

Fig. 2

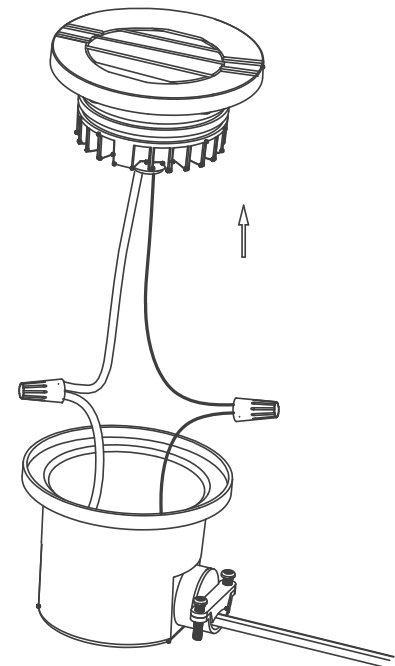
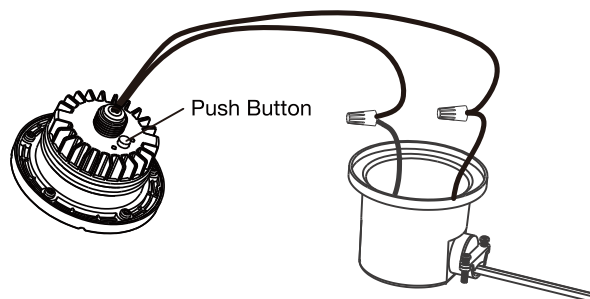

## WARRANTY

This product is warranted for 5 years from the date of purchase. If this product does not perform to the specifications supplied on this package, send an email to [support@runbisonlighting.com](mailto:support@runbisonlighting.com) for product return and replacement. This replacement is the sole remedy available. Liability for incidental or consequential damage is expressly excluded.

